



Questions?

For customer service please call us at 1-310-787-1100
Office Hours: 8:00 a.m. – 5:00 p.m. PST Monday-Friday
E-mail: info@eurilighting.com



LED 4ft.
Slim Wrap light

PLEASE REVIEW THE INSTRUCTIONS AND WARNINGS LISTED BELOW PRIOR TO PROPER INSTALLATION

WARNING	CAUTION
<ul style="list-style-type: none"> To reduce the risk of death, personal injury or property damage from fire, electric shock, falling parts, cuts/abrasions, and other hazards read all warnings and instructions included in the box and all fixture labels. Before installing, servicing, or performing routine maintenance on this equipment, follow these general precautions. Commercial installation, service and maintenance of luminaires should be performed by a qualified licensed electrician. For the installation: If you are unsure about the installation or maintenance of the luminaires, consult a qualified licensed electrician and check your local electrical code. To prevent wiring damage or abrasion, do not expose wiring to edges of sheet metal or other sharp objects. Do not make or alter any open holes in an enclosure of wiring or electrical components during kit installation. Turn off electrical power at fuse or circuit breaker box before wiring fixture to the power supply. Turn off the power when you perform any maintenance. Verify that supply voltage is correct by comparing it with the luminaire label information. All wiring connections should be capped with UL approved wire connectors. 	<ul style="list-style-type: none"> Avoid direct eye exposure to the light source while it is on. Account for small parts and destroy packing material, as these may be hazardous to children. Risk of burn. Disconnect power and allow fixture to cool before changing handing fixture. <p>NOTE:</p> <ul style="list-style-type: none"> Green ground screw provided in proper location. Do not relocate. Minimum 90° supply conductors. Specifications and dimensions subject to change without notice. Suitable for Dry or Damp location.

GENERAL WIRING DIAGRAM

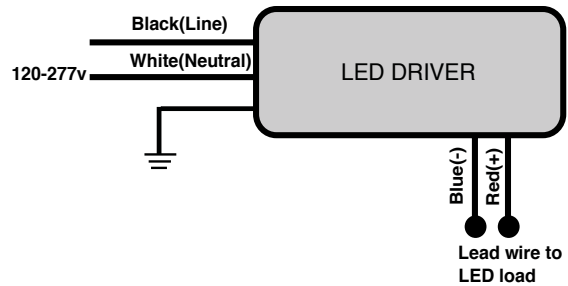

INSTALLATION INSTRUCTION - SURFACE MOUNTING(A)

Surface Mounting (A)

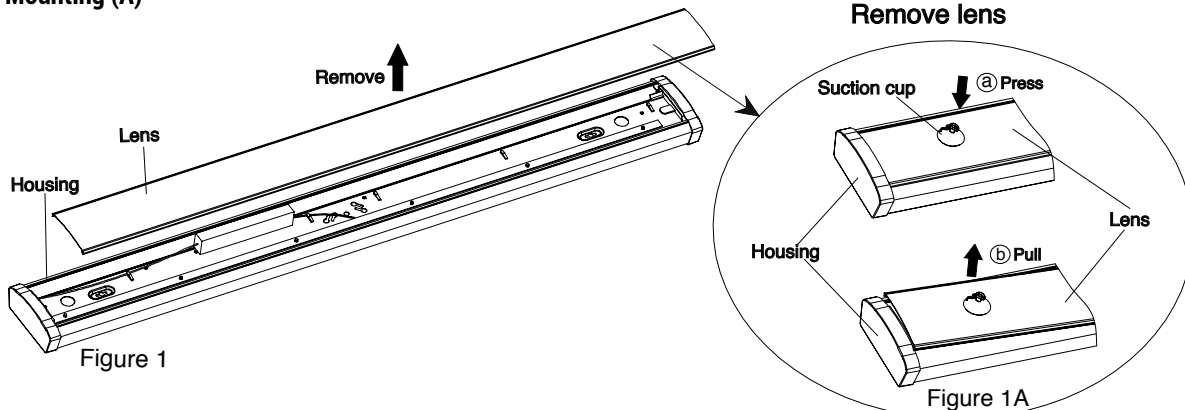

Step1: Remove the lens from the housing near one end of the housing by using the provided suction cup. Press the suction cup to absorb one side of the lens, Pull the suction cup to detach the lens from the luminaire housing (Fig. 1A detail)

Step2: Use a screwdriver to punch out one of the knocked holes and pass the electrical cable out from the housing.



Questions?

For customer service please call us at 1-310-787-1100
Office Hours: 8:00 a.m. – 5:00 p.m. PST Monday-Friday
E-mail: info@eurilighting.com



LED 4ft.
Slim Wrap light

PLEASE REVIEW THE INSTRUCTIONS AND WARNINGS LISTED BELOW PRIOR TO PROPER INSTALLATION

INSTALLATION INSTRUCTION - SURFACE MOUNTING(A)

Surface Mounting (A)

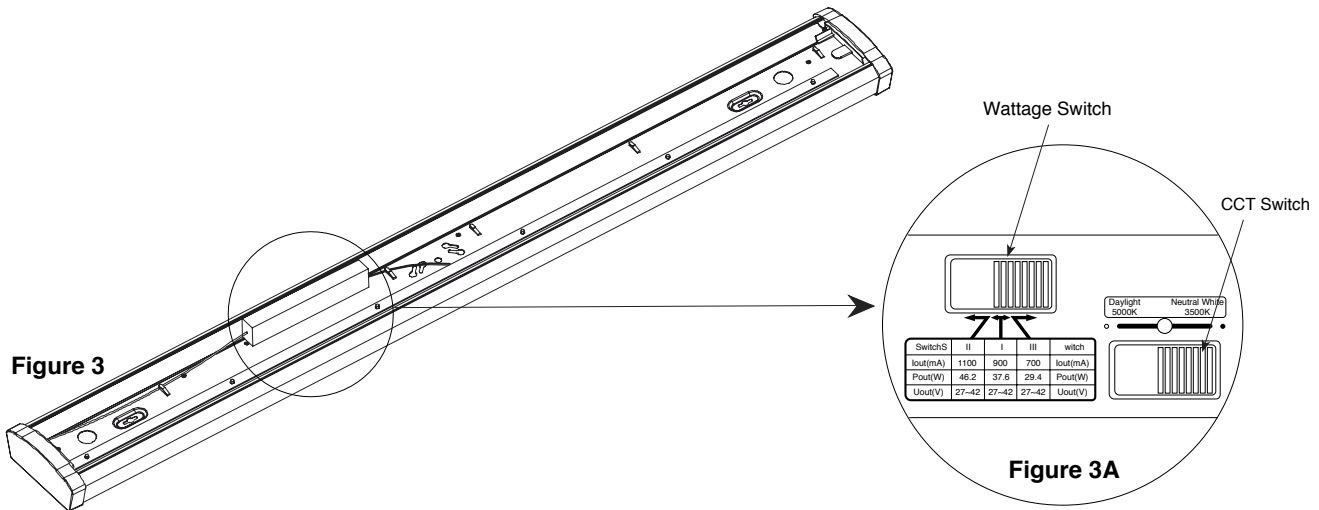
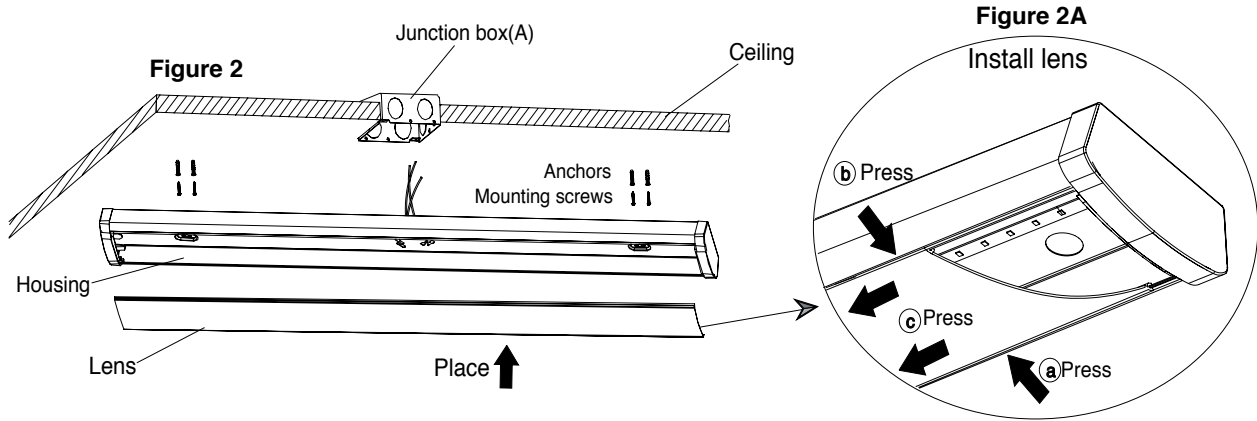

- Step3:** Use the luminaire as a template by placing it on the junction box and pencil in four hole positions in the ceiling. Put the luminaire aside and drill the four holes. Insert an anchoring bolt (not included) into each hole. Screw the four mounting screws into each anchoring bolt, then connect the AC wires.(Fig.2)
- Step4:** Choose the desired wattage and CCT. (Fig3)
- Step5:** Install the lens starting at one end of housing. Insert lens slot onto edge of housing. Carefully squeeze the lens to engage opposite side with housing. Continue this action down length of lens until fully installed onto housing.(Fig.2A detail)
- Step6:** Turn on the luminaire.



Questions?

For customer service please call us at 1-310-787-1100
Office Hours: 8:00 a.m. – 5:00 p.m. PST Monday-Friday
E-mail: info@eurilighting.com

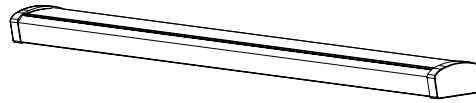

LED 4ft.
Slim Wrap light

PLEASE REVIEW THE INSTRUCTIONS AND WARNINGS LISTED BELOW PRIOR TO PROPER INSTALLATION

INSTALLATION INSTRUCTION - SURFACE MOUNTING(B)

Surface Mounting (B)

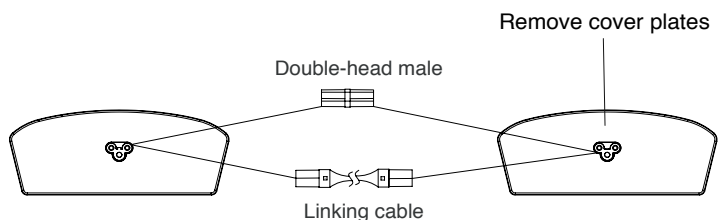
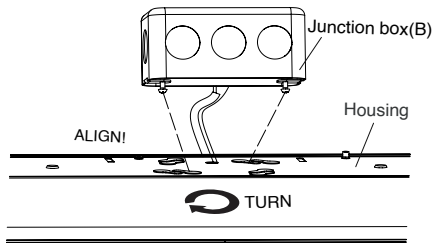
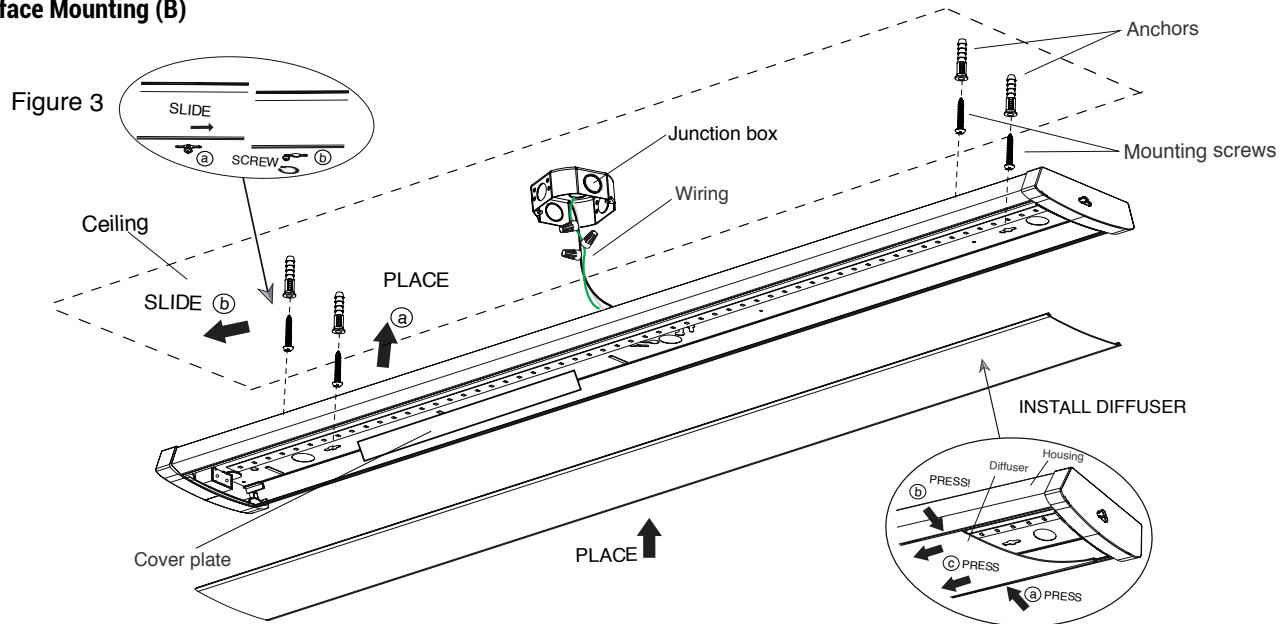

- Step 1:** Remove the lens from the housing near one end of the housing by using the provided suction cup. Press the suction cup to absorb one side of the lens, Pull the suction cup to detach the lens from the luminaire housing.
 - Step 2:** Use a screwdriver to punch out one of the knocked holes and pass the electrical cable out from the housing.
 - Step 3:** Use the luminaire as a template by placing it on the junction box and pencil in four hole positions in the ceiling. Put the luminaire aside and drill the four holes. Insert an anchoring bolt into each hole. Screw the four mounting screws into each anchoring bolt, then connect the AC wires.
 - Step 4:** Install the lens starting at one end of housing. Insert lens slot onto edge of housing. Carefully squeeze the lens to engage opposite side with housing. Continue this action down length of lens until fully installed onto housing.
 - Step 5:** After removing the cover plates, connect the luminaires by inserting the double-end male connector into the female connectors located at the each end cap of the luminaires. The number of connected fixtures must not exceed the rated setting (Max.8)
 - Step 6:** Turn on the luminaire.
- CAUTION:** If customer choose surface mounting, that mean pendant mounting won't be used.



Questions?

For customer service please call us at 1-310-787-1100
Office Hours: 8:00 a.m. – 5:00 p.m. PST Monday-Friday
E-mail: info@eurilighting.com



LED 4ft.
Slim Wrap light

PLEASE REVIEW THE INSTRUCTIONS AND WARNINGS LISTED BELOW PRIOR TO PROPER INSTALLATION

INSTALLATION INSTRUCTION - SUSPENSION MOUNTING

Suspension Mounting

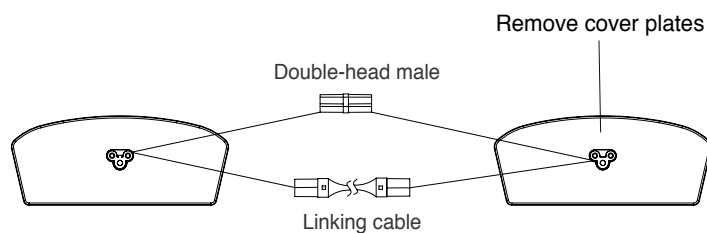
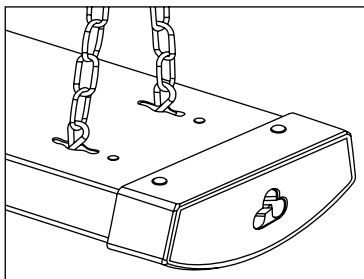
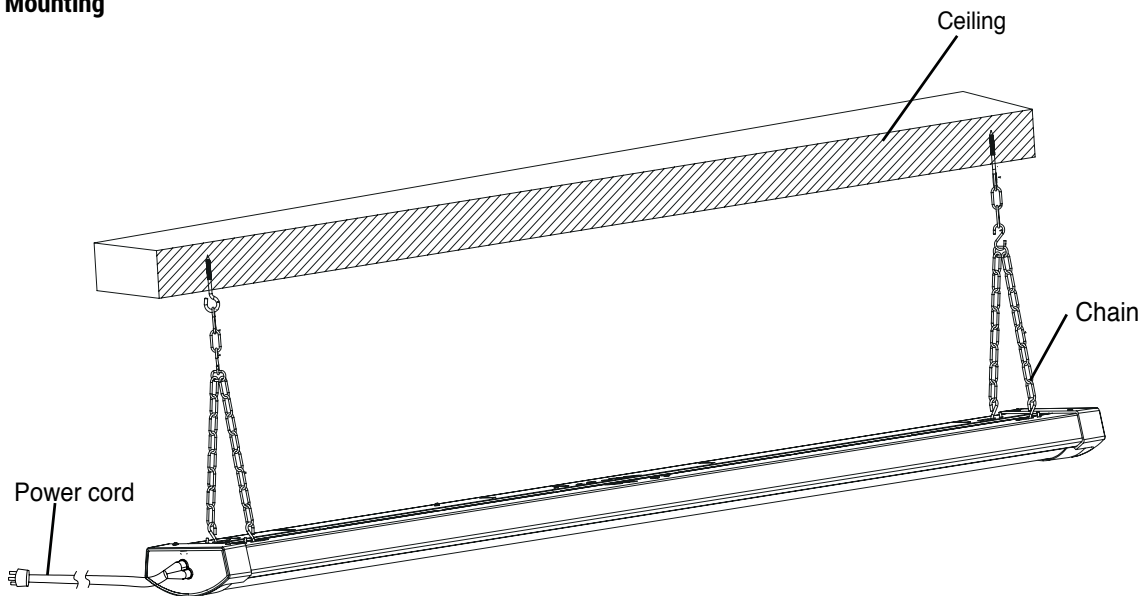

- Step 1:** Use the chains to hang the luminaires onto the ceiling.
 - Step 2:** Plug the power cord with the plug into the female connector of the only fixture that needs to be connected to the power supply.
 - Step 3:** Then use the provided dual-head male connectors to connect other required fixtures in series. The number of connected fixtures must not exceed the rated setting. (Max.8)
 - Step 4:** Turn on the luminaire.
- CAUTION:** The continuous power cord can only be plugged in AC 120V power supply.